

TLE4988C

Technical Product Description

Programmable True Power On Camshaft Sensor



About this Document

High-level description of the product features and technical characteristics as primary information about the functionality of the TLE4988C High End Camshaft Speed Sensor.

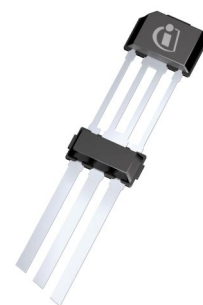

Product Description

The TLE4988C is an active Hall sensor ideally suited for camshaft applications and similar industrial applications, such as speedometer. It provides true power on (TPO) functionality from zero speed and maps the mechanical shape of a target wheel, such as either a tooth or a notch into a unique electrical output state. Variants of self-calibration algorithms are implemented, adaptable to common camshaft targets in order to achieve optimum phase accuracy in operation. TPO capability and cancelation of production spread and assembly tolerance can be achieved by end of line programming.

Features

- Mono-cell chopped Hall switching sensor to measure speed or phase of tooth/pole wheels
- Digital output signal (voltage interface) with enhanced micro break feature
- True Power On functionality (TPO) with optional automatic TPO adaption in EEPROM
- Configurable algorithms in EEPROM, incl. Individual Switching Threshold with vibration suppression
- End-of-line programmable switching points (k-factor), options for hidden, visible and adaptive switching hysteresis, programmable delay time
- Temperature coefficient of back-bias magnet pre-programmed
- High immunity against ESD, EMC and mechanical stress
- 3-pin package PG-SSO-3-52. Twist insensitive mounting (TIM). AEC-Q100 Automotive qualified
- High speed digital diagnosis test interface

Ordering Information

Table 1 **Version**

Type	Marking	Ordering Code	Package	Temp. trimming
TLE4988C-XTF-M28	88AAC1	SP005073030	PG-SSO-3-52	Ferrite
TLE4988C-XTN-M28	88AAC2	SP005072956	PG-SSO-3-52	NdFeB
TLE4988C-XTS-M28	88AAC3	SP001040468	PG-SSO-3-52	SmCo

Application Description

The TLE4988C comes in a RoHs compliant three-pin package, qualified for automotive usage. It has two integrated capacitors on the lead frame (220 nF/1.8 nF). These capacitors increase the EMC robustness of the device. In 12 V applications it is further recommended to use a serial resistor R_{Supply} (dependent on EMC requirement 47Ω to 100Ω) for protection on the supply line. A pull-up resistor R_{Load} determines the maximum current flowing through the output transistor, 1.2 kΩ is recommended.

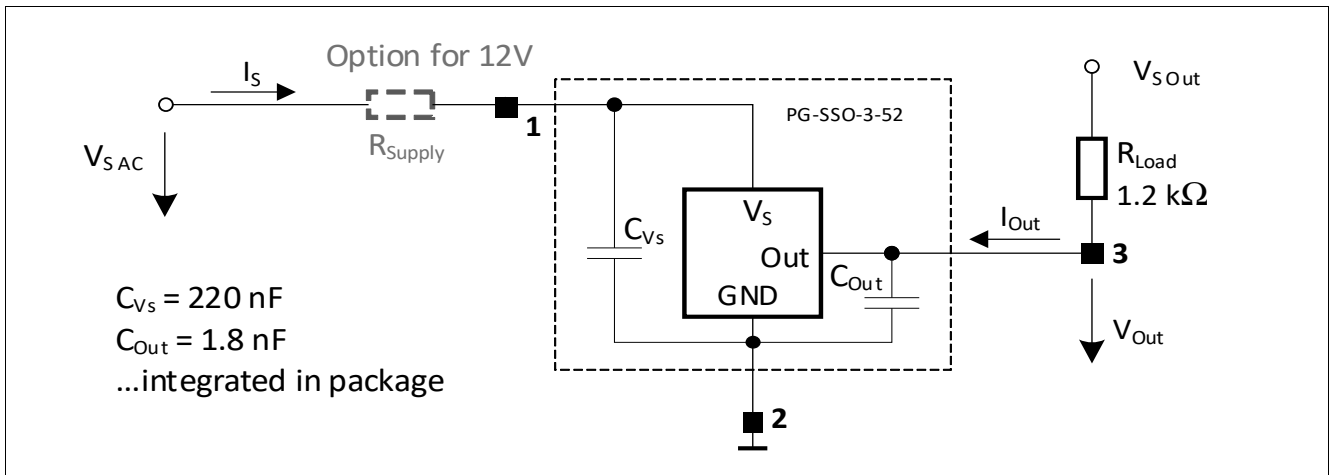

Figure 1 Typical Application Circuit

Pin Configuration

Table 2 Pin Description

Pin Number	Symbol	Function
1	$V_S (V_{DD})$	Supply Voltage
2	GND	Ground
3	$V_{OUT} (Q)$	Open Drain Output

Table of Contents

	About this Document	1
	Product Description	1
	Features	1
	Ordering Information	1
	Application Description	2
	Pin Configuration	2
	Table of Contents	3
1	General Characteristics	4
1.1	Absolute Maximum Ratings	4
1.2	Operating Range	5
2	Electrical and Magnetic Characteristics	7
3	Functional Description	8
3.1	Definition of the Magnetic Field Direction	8
3.2	Block Diagram	8
3.3	Basic Operation	8
4	Package Information	10
4.1	Package Outline	10
4.2	Packing Information	11
5	Revision History	12

General Characteristics

1 General Characteristics

1.1 Absolute Maximum Ratings

Table 3 Absolute Maximum Ratings

Parameter	Symbol	Values			Unit	Note or Test Condition
		Min.	Typ.	Max.		
Supply voltage without supply resistor	V_S	-	-	24	V	continuous $T_J \leq 175^\circ\text{C}$
		-18	-	-	V	continuous $T_J \leq 175^\circ\text{C}$
Output OFF voltage	$V_{\text{OUT_OFF}}$	-	-	26.5	V	continuous $T_J \leq 175^\circ\text{C}$
		-0.6	-		V	max. 1h, $T_J \leq 40^\circ\text{C}$
		-25	-		V	max. 60s, $T_J \leq 40^\circ\text{C}$, max 30V may not be exceeded between V_S and V_{OUT}
Output ON voltage	$V_{\text{OUT_ON}}$	-	-	16	V	continuous, $T_{\text{Amb}} \leq 40^\circ\text{C}$
Junction temperature range	T_J	-40	-	195	$^\circ\text{C}$	Exposure time: max. 10×1 h at $T_J = 195^\circ\text{C}$, $V_S = 16\text{V}$
HBM ESD immunity	V_{HBM}	± 6	-	-	kV	The product shall withstand the specified min. ESD voltage acc. to HBM ESD test standard ANSI/ESDA/JEDEC JS-001
CDM ESD immunity	V_{CDM}	± 0.75	-	-	kV	The product shall withstand the specified min. ESD voltage acc. to CDM ESD test standard ANSI/ESDA/JEDEC JS-002-2014

Note: Stresses above the max values listed here may cause permanent damage to the device. Exposure to absolute maximum rating conditions for extended periods may affect device reliability. Maximum ratings are absolute ratings; exceeding only one of these values may cause irreversible damage to the integrated circuit.

General Characteristics

1.2 Operating Range

All parameters specified in the following sections refer to these operating conditions unless otherwise specified.

Table 4 General Operating Conditions

Parameter	Symbol	Values			Unit	Note or Test Condition
		Min.	Typ.	Max.		
Supply voltage without supply resistance R_s	V_S	4	–	24	V	$T_J \leq 175^\circ\text{C}$
Supply voltage with supply resistance R_s (AC... application circuit)	V_{SAC}	5	–	24	V	$R_s = 47\Omega$ to 100Ω recommended, depending on EMC requirements, $T_J \leq 175^\circ\text{C}$
Continuous Output Off voltage	V_{OUT_OFF}	0	–	26.5	V	$T_J \leq 175^\circ\text{C}$
Continuous output On current	I_{OUT_ON}		–	15	mA	Load
Capacitance between IC supply and ground pins	C_{Vs}	198	220	242	nF	
Output capacitance between IC output and ground pins	C_{Out}	1.62	1.8	1.98	nF	
Magnetic signal frequency range for camshaft applications	f_{CAM}	0	–	5000	Hz	
Full scale range of the magnetic field	FSR_{mag_field}	-31.1	-	134.6	mT	TLE4988C-XTN-M28, TLE4988C-XTS-M28
		-15	-	80	mT	TLE4988C-XTF-M28
Maximum peak to peak field amplitude in full scale range	B_{pp_max}	-	-	147	mT _{pp}	TLE4988C-XTN-M28, TLE4988C-XTS-M28
		-	-	95	mT _{pp}	TLE4988C-XTF-M28
Magnetic range for TPO and switching threshold	$B_{threshold}$	-31.1	–	100	mT	TLE4988C-XTN-M28, TLE4988C-XTS-M28 Allowed programmable TPO, Hysteresis not included
		-15	–	45	mT	TLE4988C-XTF-M28 Allowed programmable TPO, Hysteresis not included
Normal operating junction temperature	T_J	-40	–	175	$^\circ\text{C}$	Exposure time limited
		-	-	185	$^\circ\text{C}$	Exposure time limited. Degraded performance

Note: In the operating range the functions given in the functional description are fulfilled

General Characteristics

1.2.1 Temperature Coefficient

Table 5 Temperature Coefficients

Parameter	Symbol	Values			Unit	Note or Test Condition
		Min.	Typ.	Max.		
Pre-programmed (trimmed) temperature coefficient	TC	-	-600	-	ppm/K	TLE4988C-XTS-M28, trimming for SmCo
		-	-1200	-	ppm/K	TLE4988C-XTN-M28, trimming for NdFeB
		-	-2000	-	ppm/K	TLE4988C-XTF-M28, trimming for Ferrite

Electrical and Magnetic Characteristics

2 Electrical and Magnetic Characteristics

All values specified at constant amplitude and offset of input signal, over operating range, unless otherwise specified. Typical values correspond to $V_S = 5\text{ V}$ and $T_{Amb.} = 25^\circ\text{C}$

Table 6 Electrical and Magnetic Parameters

Parameter	Symbol	Values			Unit	Note or Test Condition
		Min.	Typ.	Max.		
Output saturation voltage	V_{Qsat}	-	-	300	mV	$I_{Out} = 5\text{ mA}$
Supply current	I_S	4	6.7	8.8	mA	
Output leakage current	$I_{Outleak}$	-	0.1	10	μA	
Output current limit during short-circuit condition	$I_{Outshort}$	25	-	80	mA	
Output rise time	t_{rise}		4.8	9.1	μs	Application parameter, 10% - 90%
Output fall time	t_{fall}	4.6 1.2	7.3 2.4	10.1 3.6	μs	$V_{Sout} = 12\text{ V}$, 90% - 10%, selectable
Output fall time	t_{fall}	3 0.5	4 1	5 1.5	μs	$V_{Sout} = 5\text{ V}$, 90% - 10%, selectable
Power on time	t_{power_on}	0.8	0.9	1	ms	During this time the output is locked to high
Delay time between magnetic signal switching point and corresponding output edge	t_d		19		μs	
Additional programmable delay time	t_{d_prog}		4		μs	programmable for 0 to 7 steps for typical 0 to 28 μs additional delay time
Resolution of linearized and temperature compensated magnetic field value (BLIN)	B_{BLIN_res}		9.16		$\mu\text{T}/\text{LSB}$	
Hysteresis Option 1 - 5	B_{Hys}		1.4		mT	Valid at room temperature. Selectable
			3		mT	
			4		mT	
			6.2		mT	
			6.8		mT	
Adjustment range of switching level (k-factor)	K_factor	25	-	75	%	Programmable step size 0.78125%

Functional Description

3 Functional Description

3.1 Definition of the Magnetic Field Direction

The magnetic field of a permanent magnet exits from the north pole and enters the south pole. If a north pole is attached to the backside of the TLE4988C, the field at the sensor position is positive.

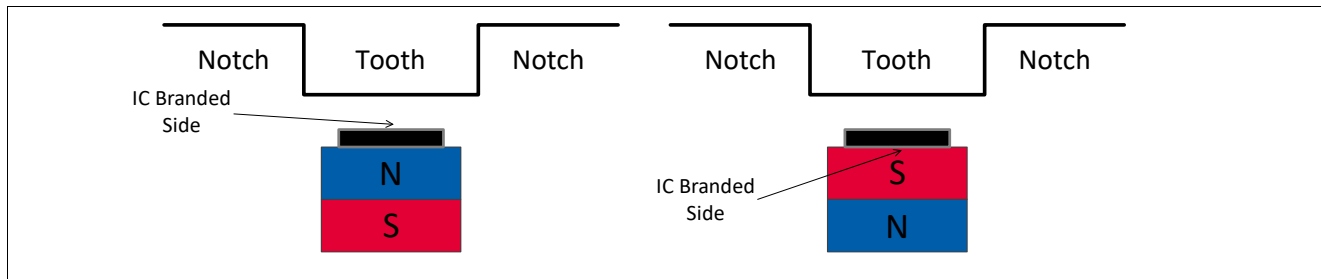

Figure 2 Definition of the Positive Magnetic Field Direction

3.2 Block Diagram

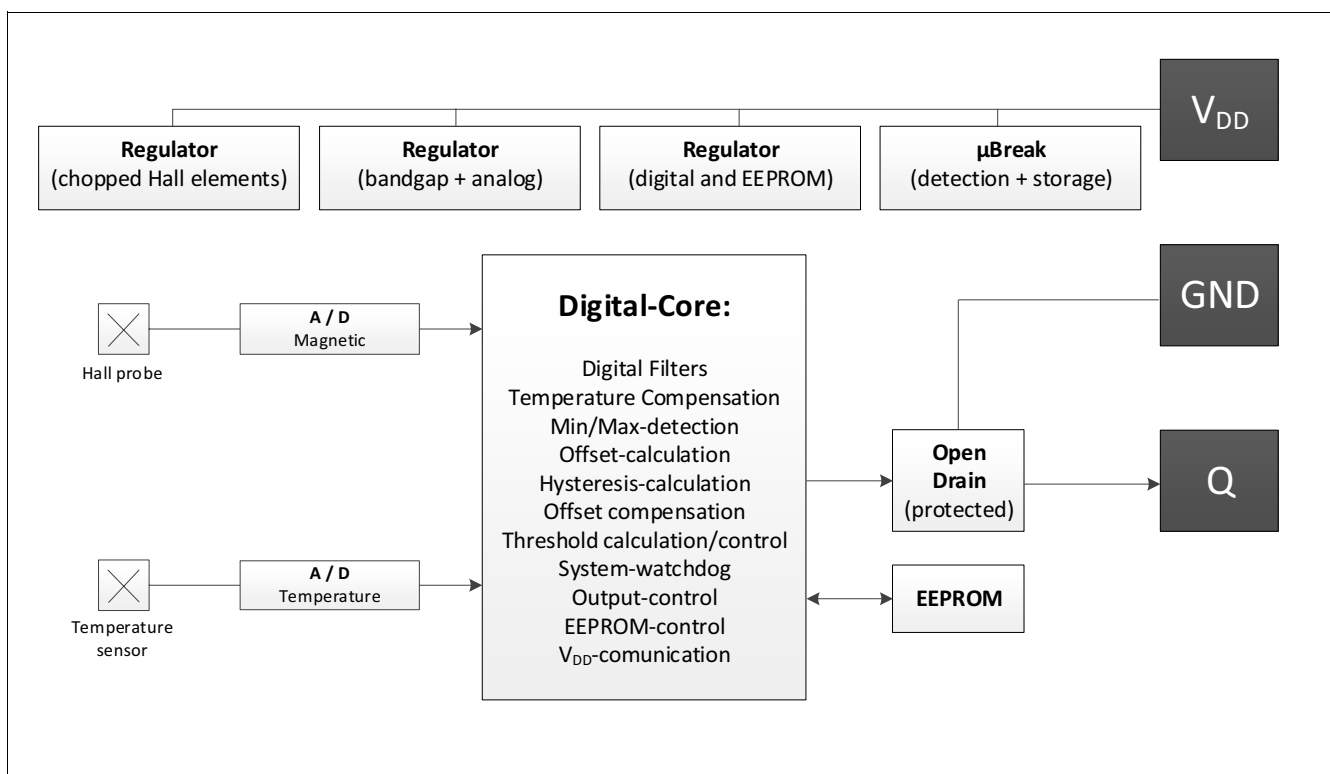

Figure 3 Block Diagram

3.3 Basic Operation

The basic operation of the TLE4988C is to map the magnetic field produced by a spinning target wheel into high/low states at the output pin. The high/low ratio on the output signal is given by the tooth/notch ratio of ferromagnetic target wheels, but also according to the duty cycle of magnetic encoder wheels. The correspondence between field polarity and output polarity can be set according to the application needs. By definition a magnetic field is considered as positive if the magnetic North Pole is placed at the rear side of the sensor (Figure 2).

Functional Description

The operation has four different phases:

- Power-on phase: loads EEPROM data for trimming coefficients and algorithm, allows signal path to stabilize
- Initial phase: sets the output polarity according to the magnetic field, True-Power-On functionality
- Calibration phase: adapts the threshold to the magnetic field based on extrema detection
- Running phase: the threshold is considered calibrated for optimal phase accuracy, only minor threshold corrections are allowed

Various choices of algorithm variants and functional features are available:

- Max/Min detection, Averaging of extrema or teeth Individual Switching Thresholds
- Fast Calibration mode
- Auto TPO adaption
- Event Watchdog options
- Visible or hidden Hysteresis, fix or adaptive
- Selectable k-factor during calibration and in running state, optional adaptive to amplitude
- Additional programmable delay time

For ideal configuration to application needs a serial interface is implemented and used to set and program EEPROM parameter of the sensor IC. Additionally, for the purpose of in situ diagnosis in application, or ADC data readout on higher rotational speed the Fast Data Readout mode is implemented.

Revision History

5 Revision History

Revision	Date	Changes
1.0	2020-03-20	Initial version

Trademarks of Infineon Technologies AG

μ HVIC™, μ IPM™, μ PFC™, AU-ConvertIR™, AURIX™, C166™, CanPAK™, CIPOS™, CIPURSE™, CoolDP™, CoolGaN™, COOLiR™, CoolMOS™, CoolSET™, CoolSiC™, DAVE™, DI-POL™, DirectFET™, DrBlade™, EasyPIM™, EconoBRIDGE™, EconoDUAL™, EconoPACK™, EconoPIM™, EiceDRIVER™, eupec™, FCOS™, GaNpowIR™, HEXFET™, HITFET™, HybridPACK™, iMOTION™, IRAM™, ISOFACE™, IsoPACK™, LEDriviR™, LITIX™, MIPAQ™, ModSTACK™, my-d™, NovalithIC™, OPTIGA™, OptiMOS™, ORIGA™, PowIRaudio™, PowIRstage™, PrimePACK™, PrimeSTACK™, PROFET™, PRO-SIL™, RASIC™, REAL3™, SmartLEWIS™, SOLID FLASH™, SPOC™, StrongIRFET™, SupIRBuck™, TEMPFET™, TRENCHSTOP™, TriCore™, UHVIC™, XHP™, XMC™.

Trademarks updated November 2015

Other Trademarks

All referenced product or service names and trademarks are the property of their respective owners.

Edition 2020-03-20

Published by

Infineon Technologies AG

81726 Munich, Germany

© 2020 Infineon Technologies AG.

All Rights Reserved.

Do you have a question about any aspect of this document?

Email: erratum@infineon.com

IMPORTANT NOTICE

The information given in this document shall in no event be regarded as a guarantee of conditions or characteristics ("Beschaffheitsgarantie").

With respect to any examples, hints or any typical values stated herein and/or any information regarding the application of the product, Infineon Technologies hereby disclaims any and all warranties and liabilities of any kind, including without limitation warranties of non-infringement of intellectual property rights of any third party.

In addition, any information given in this document is subject to customer's compliance with its obligations stated in this document and any applicable legal requirements, norms and standards concerning customer's products and any use of the product of Infineon Technologies in customer's applications.

The data contained in this document is exclusively intended for technically trained staff. It is the responsibility of customer's technical departments to evaluate the suitability of the product for the intended application and the completeness of the product information given in this document with respect to such application.

For further information on technology, delivery terms and conditions and prices, please contact the nearest Infineon Technologies Office (www.infineon.com).

WARNINGS

Due to technical requirements products may contain dangerous substances. For information on the types in question please contact your nearest Infineon Technologies office.

Except as otherwise explicitly approved by Infineon Technologies in a written document signed by authorized representatives of Infineon Technologies, Infineon Technologies' products may not be used in any applications where a failure of the product or any consequences of the use thereof can reasonably be expected to result in personal injury.

Mouser Electronics

Authorized Distributor

Click to View Pricing, Inventory, Delivery & Lifecycle Information:

[Infineon:](#)

[TLE4988CXTNM28HAMA1](#) [TLE4988CXTSM28HAMA1](#) [TLE4988CXTFM28HAMA1](#)